



GoldNet Pty Limited ABN 42 127 052 493

BUSINESS DATA SERVICES

STANDARD FORM OF AGREEMENT

INTRODUCTION

This document is GoldNet Pty Limited ("GoldNet")'s Standard Form of Agreement ("Agreement"). This document should be read as a whole. If You are an "ordinary person" then this Agreement is formulated and provided to you for the purposes of section 479 of the *Telecommunications Act 1997* (Cth) (the "Act") and it sets out the terms and conditions under which GoldNet's service is supplied to You. If you are a company or not an "ordinary person", then it also sets out the terms and conditions upon which You agree to be supplied with Services from GoldNet. Some of the clauses in this contract may affect the way You use the service or the way in which You deal with GoldNet.

The Agreement includes the terms and conditions contained in this document, together with any specific terms and conditions contained in a Schedule to this document, an approved Application Form, the GoldNet Acceptable Use Policy and the GoldNet Privacy Policy, all of which are hereby incorporated by reference. In accordance with GoldNet's requirements under the Act, copies of this Agreement are available to the public from our business offices at Shop 1, 97 Forrest Street, Kalgoorlie, Western Australia 6430. The Agreement is also available on GoldNet's website, <http://www.gold.net.au>.

GoldNet may vary the GoldNet Privacy Policy, the GoldNet Acceptable Use Policy, the Charges, the speed of a Service and any other terms and conditions contained in this Agreement and any other documents which comprise or are incorporated into this Agreement, at any time, subject to the requirements and our obligations under the Act and as set out in the Agreement.

IF YOU HAVE ANY QUESTIONS YOU CAN CONTACT US AS FOLLOWS:

Contact Method	Details
TELEPHONE:	08 90805111
EMAIL:	smorgan@gold.net.au
IN PERSON:	Shop 1, 97 Forrest Street, Kalgoorlie WA 6430



1. Definitions and Interpretation

1.1 In this Agreement:

Acceptable Use Policy means the conditions of use applicable to the Service as varied from time to time, a copy of which is available online at <http://www.gold.net.au/legal/>;

Application Form means an online or paper-based form designated by GoldNet for the purposes of the Agreement, completed by the Customer and submitted to GoldNet;

Charges means the charges payable by the Customer to GoldNet pursuant to the Agreement including, but not limited to, access, rental and usage fees relative to the Service and the CPE. The Charges are specified in Schedule 1 and Schedule 4;

Commencement Date means the date requested for commencement of the Service in the Application Form;

Customer or You or Your are all references to the entity who obtains a Service and/or CPE from GoldNet under the Agreement following the submission of an Application Form and the approval of the Application Form by GoldNet;

Customer Premises Equipment or CPE means telecommunications equipment supplied to the Customer and/or installed at the Customer's premises or other location designated by the Customer, for the purpose of facilitating the Customer's connection to a Service, more particularly described in Schedule 2;

Force Majeure means a circumstance beyond the reasonable control of GoldNet which results in GoldNet being unable to observe or perform on time an obligation under the Agreement. Such circumstances include but are not limited to:

- (a) acts of God, lightning strikes, earthquakes, floods, storms, explosions, fires and any natural disaster;
- (b) acts of war, acts of public enemies, terrorism, riots, civil commotion, malicious damage, sabotage and revolution; and
- (c) malfunction of a telecommunications network, CPE or a Service not controlled or operated by GoldNet;

Internet means the worldwide connection of computer networks providing for the transmittal of electronic mail, on-line information, information retrieval and other communication;

Party means GoldNet or the Customer (as the context dictates) and Parties means both GoldNet and the Customer;

Schedule means a schedule to this Agreement; and

Service means the service(s) provided by GoldNet to the Customer and requested by the Customer in an Application Form. The details of the Services available from GoldNet are more particularly set out in Schedule 1.

1.2 Interpretation

- (a) the clause headings are for convenient reference only and have no effect in limiting or extending the language of the provisions to which they refer;
- (b) a cross reference to a clause number is a reference to its subclauses;
- (c) words in the singular number include the plural and vice versa;
- (d) words importing a gender include any other gender;
- (e) a reference to a person includes a partnership and a body, whether corporate or otherwise;
- (f) a reference to a clause is a reference to a clause or subclause of this Agreement;
- (g) a reference to a subclause is a reference to a subclause of the clause in which that reference is made;
- (h) where a word or phrase is given a particular meaning, other parts of speech and grammatical forms of that word or phrase have corresponding meanings;
- (i) a reference to a Schedule includes a reference to any part of that Schedule which is not physically annexed to this Agreement but which is incorporated by reference;
- (j) monetary references are references to Australian currency;
- (k) the words "includes" and "including" are not words of limitation; and
- (l) the contra proferentem rule shall not apply.

2. Supply of the Service

2.1 Without limiting any other terms and conditions of the Agreement, the Agreement and the supply by GoldNet of the Service to the Customer shall at all times be subject to:

- (a) GoldNet's approval of the Customer's Application Form (such approval being subject to GoldNet's absolute discretion);
- (b) successful installation of the CPE at the premises nominated by the Customer in an Application Form;
- (c) continuous compliance by the Customer at all times with all of its material obligations under this Agreement (including payment obligations); and
- (d) expiry or early termination of this Agreement where permissible under this Agreement.

2.2 Without limiting GoldNet's rights of termination otherwise specified in the Agreement or at law, GoldNet reserves the right to immediately, and without notice to the Customer, withdraw the Customer's access to the Service if:

- (a) the Customer fails to comply with any provision of this Agreement after being given 14 days notice to remedy a breach;



- (b) the Customer provides false or inaccurate information on an Application Form;
- (c) the location for connection of the Service and installation of the CPE is or becomes unsuitable for technical reasons, in GoldNet's absolute discretion;
- (d) GoldNet reasonably suspects illegal conduct by any Customer or user of the Customer's Service;
- (e) there is a threat or risk to the security of a Service or integrity of the GoldNet network;
- (f) GoldNet is unable to supply the Service to the Customer because a supplier has withdrawn from GoldNet its carriage service necessary to supply the Service to the Customer;
- (g) there is an emergency; and/or
- (h) to comply with legal requirements.

3. CPE Installation, Service Connection and Service Availability

3.1 The Service is only offered to approved Customers. In completing an Application Form, You:

- (a) warrant that You have the authority to apply for the Service;
- (b) agree and acknowledge that You remain liable for all amounts owed to Your existing telecommunications supplier if payable by You as a result of Your transfer of any telecommunications service to GoldNet and/or termination of any agreement with the existing supplier under Your agreement with that supplier; and
- (c) agree wholly and unconditionally to the terms and conditions of the Agreement.

3.2 GoldNet will endeavour to connect the Service at the Customer's premises, as soon as practicable. The Customer agrees to cooperate with GoldNet so as to enable such connection and the installation of the CPE including via granting GoldNet access to the premises of the Customer at all or any times required by GoldNet and during all such access and any subsequent access for maintenance or other purposes the Customer agrees to provide full, free and unfettered access to the CPE and the Customer's premises and a suitable and safe working environment for GoldNet, its representatives, agents, and installers. Indicative service connection times are as follows:

Connection	Connection Timeframe
GoldNet Enabled	Within 30 Business Days After Request
Non-GoldNet Enabled	Within 60 Business Days After Request



Non-GoldNet Enabled
(Major Network
Extension Required)

By negotiation

- 3.3 The Customer acknowledges that the CPE may only be installed and configured by GoldNet and the CPE is and shall remain at all times (including following termination or expiry of this Agreement), the sole property of GoldNet. Ownership or title in the CPE does not transfer to You when you use the Service. You hold the CPE on behalf of GoldNet for the duration of the Agreement.
- 3.4 We will repair or replace the CPE during the term of the Agreement due to any malfunction. However, we will charge You for any loss or damage to the CPE where such loss or damage was caused by Your act or omission. Security of the CPE is Your responsibility.
- 3.5 Further terms and conditions related to the CPE are set out in Schedule 2.
- 3.6 GoldNet shall use its best endeavours to supply the Customer with the Service 24 hours per day, 7 days per week but does not warrant the Service will be supplied on an uninterrupted basis.
- 3.7 If the Service is inaccessible by the Customer due to GoldNet maintenance, GoldNet shall use its best endeavours to so notify the Customer of the time required for the maintenance via any of the contact details specified by the Customer in the Application Form.
- 3.8 The Service Levels and rebates contained in Schedule 3 shall apply however GoldNet shall not be liable for any delay or failure to perform its obligations pursuant to this Agreement if such delay is due to Force Majeure.
- 3.9 If a delay or failure of GoldNet to perform its obligations is caused or anticipated due to Force Majeure, the performance of GoldNet's obligations hereunder will be suspended.
- 3.10 GoldNet has no responsibility to provide any computer equipment, electricity connection or training in the use of the Service or CPE pursuant to this Agreement or at all.
4. Use of the CPE and the Service
- 4.1 The Customer agrees to comply with all guides, manuals, recommendations and directions pertaining to the access and use of the Service and CPE given to the Customer by GoldNet from time to time including, but not limited to, those directions specified in the Acceptable Use Policy.
- 4.2 The Customer warrants that in accessing and using the Service it will only use software that it is legally entitled to use and that such use will not be a breach of copyright.



- 4.3 The Customer acknowledges that GoldNet does not and cannot in any way supervise, edit or control the content and form of any information or data accessed through the Service and GoldNet shall not be held responsible in any way for any content or information accessed via the Service.
- 4.4 GoldNet disclaims all or any liability for any material on the Internet of that is otherwise transmitted via the Service that the Customer finds offensive, upsetting, defamatory, personally offensive or in any way unsuitable for people under the age of eighteen (18). The Customer agrees to provide adult supervision of the use of the Service and CPE if used by people under the age of eighteen (18).
- 4.5 The Customer will not act on or through the Service so as to interfere with or disrupt Internet users, service providers, their computers, software or hardware. Such actions include, but are not limited to, the circulation of any unsolicited publicity or advertising material, propagation of computer worms and viruses, using the Service to make an unauthorised access of any other computer accessible via the Internet, sending harassing, obscene, indecent, offensive or threatening electronic mail, forgery (or attempted forgery) of electronic mail messages and the placement, transmission or storage of any defamatory material on the Internet.
- 4.6 The Customer agrees to refrain from the bulk transmission of messages to unsuitable Internet users, service providers or newsgroups. The Customer agrees to refrain from the bulk transmission of unsolicited electronic mail.
- 4.7 The Customer will not access, nor permit any other party to access, any Service for any purpose or activity of an illegal, fraudulent or defamatory nature.
- 4.8 The Customer will not reproduce, distribute, transmit, publish, copy, transfer or commercially exploit any information accessed through or received from a Service that would be an infringement of any copyright, patent, trademark, design or other intellectual property right.
- 4.9 The Customer will prepare and maintain sufficient and frequent back-up files and data storage capacity for the Customer's data including electronic messages and the Customer understands GoldNet shall not be responsible for the back-up or retention of any electronic messages or other files of the Customer which may be stored on GoldNet's computer servers.
- 4.10 The Customer warrants that it is not a carrier or carriage service provider and agrees that it shall not under any circumstances resell or resupply any Service.
- 4.11 The Customer may only access the Service using the CPE configured for connection to the Service by GoldNet and only at the premises specified on the Application Form.

- 4.12 You acknowledge that to use the Service, GoldNet may need to allocate to You one or more identifiers such as a telephone number, an IP address or a domain name. These are not owned and controlled by GoldNet and GoldNet must comply with the Australian Communications and Media Authority's regulations, the *Telecommunications Numbering Plan*, and any directions from the administrators of domain names. GoldNet will notify you in writing at your specified address as soon as is reasonably possible if GoldNet is required at law to reallocate or reassign a telephone number, IP address or domain name.
5. Charges
- 5.1 The Customer shall pay the Charges according to the price in Schedule 1 specified for the Service. Where a Service plan specifies a maximum monthly transmission limit (specified in gigabytes), the Customer must still pay the applicable monthly charge if the maximum monthly transmission limit is not reached and where the maximum monthly transmission limit is exceeded, any applicable excess usage charges. Any unused bandwidth in any month expires at the end of that month.
- 5.2 Miscellaneous fees specified in Schedule 4 are also payable by the Customer, payable in arrears.
- 5.3 The Charges for any rental of CPE must be paid each month, in advance.
- 5.4 The Charges for Service usage must be paid each month, in arrears.
- 5.5 GoldNet issues invoices on a monthly basis. All Charges must be paid within 30 days of invoice, without setoff, counterclaim or deduction, via direct credit to a bank account nominated by GoldNet.
- 5.6 If the Customer disputes the whole or any portion of the amount claimed in an invoice submitted by GoldNet, the Customer shall pay the entire amount stated in the invoice and shall notify GoldNet in writing (within 7 days of receipt of the invoice) of the reasons for disputing the invoice. GoldNet will, within 30 days of receiving such notification, notify the Customer of its decision regarding the dispute, which shall be final.
- 5.7 The Customer shall pay GoldNet interest at the rate of 10% per annum on any Charges invoiced and not paid by the Customer within the time required by this Agreement, on top of the amount invoiced by GoldNet.
- 5.8 The Charges are exclusive of Goods and Services Tax and all other taxes, duties and charges imposed or levied in Australia or overseas in connection with the supply of the Services. Without limiting the foregoing, the Customer shall be liable for GST and for any new taxes, duties or charges imposed subsequent to the date of this Agreement in respect of the CPE and/or the Services.



5.9 GoldNet shall notify the Customer of the Charges due each month in the form of a tax invoice sent via email. An invoice issued by GoldNet shall be deemed to be correct and prima facie evidence of all connection, access, usage and other fees and Charges specified therein.

6. Indemnity

6.1 The Customer releases and indemnifies GoldNet, its servants and agents against all loss and all actions, claims and demands (including the cost of defending or settling any action, claim or demand) which may be instituted against GoldNet arising out of a breach of this Agreement by the Customer or any wilful, unlawful or negligent act or omission or negligence of the Customer, its agents, employees or sub-contractors or of any other person for whose acts or omissions the Customer is vicariously liable.

7. Implied terms

7.1 Subject to subclause 2, any condition or warranty which would otherwise be implied in this Agreement is hereby excluded.

7.2 Where legislation implies in this Agreement any condition or warranty, and that legislation prohibits provisions in a contract excluding or modifying the application of or exercise of, liability under such condition or warranty, the condition or warranty shall be deemed to be included in this Agreement. However, the liability of GoldNet for any breach of such condition or warranty shall be limited, at the option of GoldNet, to one or more of the following:

(a) if the breach relates to goods:

- (i) the replacement of the goods or the supply of equivalent goods;
- (ii) the repair of such goods;
- (iii) the payment of the cost of replacing the goods or of acquiring equivalent goods; or
- (iv) the payment of the cost of having the goods repaired; and

(b) if the breach relates to services:

- (i) the supplying of the services again; or
- (ii) the payment of the cost of having the services supplied again.

7.3 Clause 7.2 does not apply if you purchased the goods or services for personal, domestic or household use.

8. Liability of GoldNet

8.1 GoldNet may be able to exclude liability to You, where it is reasonable and fair to do so, if GoldNet is not able to perform its obligations under the Agreement because of an event that is reasonably outside our control such as due to Force Majeure.



8.2 The Customer acknowledges that to the extent GoldNet has made any representation which is not otherwise expressly stated in this Agreement, the Customer has been provided with an opportunity to independently verify the accuracy of that representation.

9. Termination and Suspension

9.1 Without limiting the generality of any other clause in this Agreement, GoldNet may terminate this Agreement immediately by notice in writing if:

- (a) it is demonstrated the Customer is in breach of any material term of this Agreement (including, in relation to payment for the CPE or Services, the care of CPE, or where the Customer is in breach of the Acceptable Use Policy) and such breach is not remedied within fourteen (14) days of the Customer being notified of the breach by GoldNet;
- (b) the Customer becomes, threatens or resolves to become or is in jeopardy of becoming subject to any form of bankruptcy, winding up, administration, receivership, liquidation or other insolvency administration;
- (c) the Customer, being a partnership, dissolves, threatens or resolves to dissolve or is in jeopardy of dissolving;
- (d) the Customer, being a natural person, dies;
- (e) the Customer ceases or threatens to cease conducting its business in the normal manner;
- (f) if GoldNet determines in its absolute discretion it is absolutely necessary to do so due to a technical emergency;
- (g) GoldNet is required to do so by order of a court or tribunal with jurisdiction; or
- (h) a competition notice which affects the subject matter of this Agreement is issued by the Australian Competition and Consumer Commission.

9.2 If notice is given to the Customer pursuant to subclause 1, GoldNet may, in addition to terminating the Agreement:

- (a) retain any moneys paid;
- (b) charge a reasonable sum for services supplied in respect of which work no sum has been previously charged;
- (c) be regarded as discharged from any further obligations under this Agreement;
- (d) require the Customer to pay the relevant monthly Charges multiplied by the number of months remaining in the minimum term plus any other outstanding fees and charges owing by the Customer to GoldNet. The Customer acknowledges this is not a penalty but is rather a reasonable estimate of the loss and damage GoldNet will suffer due to such early termination; and
- (e) pursue any additional or alternative remedies provided by law.



10. Sub-contracts

10.1 GoldNet may sub-contract for the performance of this Agreement or any part of this Agreement.

10.2 GoldNet may, without the consent of the Customer, engage individuals on a sub-contract or consultancy basis, whether or not operating under a corporate structure, to assist in the provision of the Services or installation or maintenance of CPE.

11. Entire agreement

This Agreement constitutes the entire agreement between the Parties and supersedes all prior representations, agreements, statements and understandings, whether verbal or in writing.

12. Assignment

12.1 The Customer shall not assign or novate the whole or part of this Agreement to another party without the prior written consent of GoldNet.

12.2 GoldNet may assign or novate the whole or part of this Agreement to another party without the prior written consent of the Customer.

13. Waiver

13.1 No term of this Agreement shall be deemed to be waived except by notice in writing signed by each Party.

13.2 A waiver made by GoldNet pursuant by subclause 1 will not prejudice its rights in respect of any subsequent breach of the Agreement by the Customer.

13.3 Subject to subclause 1, any failure by GoldNet to enforce any clause of this Agreement, or any forbearance, delay or indulgence granted by GoldNet to the Customer, will not be construed as a waiver of GoldNet's rights under this Agreement.

14. Severability

14.1 If any provision of this Agreement is held invalid, unenforceable or illegal for any reason, the Agreement shall remain otherwise in full force apart from such provisions which shall be deemed deleted.

15. GoldNet's rights

15.1 Any express statement of the right of GoldNet under this Agreement is without prejudice to any other right of GoldNet expressly stated in this Agreement or existing at law.

16. Survival of agreement

16.1 The covenants, conditions and provisions of this Agreement which are capable of having effect after the expiration of the Agreement shall remain in full force and effect following the expiration of the Agreement.

17. Governing law



- 17.1 This Agreement will be governed by and construed according to the laws of New South Wales, and the Parties submit to the exclusive jurisdiction of the courts of New South Wales and any courts which have jurisdiction to hear appeals from decisions of those courts.
18. Notices
- 18.1 Notices under this Agreement may be delivered by hand, by email, by mail or by facsimile to either Party.
- 18.2 Notice will be deemed given:
- (a) in the case of hand delivery by either Party, upon written acknowledgment of receipt by an officer or other duly authorised employee, agent or representative of the receiving Party;
 - (b) in the case of posting by either Party, three days after despatch;
 - (c) in the case of facsimile by either Party, upon receipt of transmission if received on a business day or otherwise at the commencement of the first business day following transmission;
 - (d) where sent by email by the Customer to GoldNet, upon receipt by the Customer of written acknowledgement from GoldNet confirming the delivery of the email to GoldNet;
 - (e) where sent by email by GoldNet to Customer, upon the email being confirmed as sent on GoldNet's email system.
- 18.4 The address for service of notices on the Customer is the address specified by the Customer in the Application Form.
19. Privacy and Security
- 19.1 You acknowledge and agree that any personal information you provide to GoldNet or submit over GoldNet's network is subject to the GoldNet Privacy Policy and you consent to GoldNet's use of Your personal information in accordance with that Privacy Policy.
- 19.2 The Customer is responsible for maintaining the secrecy and confidentiality of all identification and log-in information required by the Customer to access any Service.
- 19.3 The Customer agrees not to disclose to any other person, corporation, entity or organisation any identification or log-in information, whether in use or not, nor any other confidential information relating to any Service or of GoldNet.
- 19.4 The Customer is liable for all fees and Charges resulting from use of the Service accessed through the Customer's identification or log-in information, whether authorised by the Customer or not. Disclosure or loss of identification or log-in information that results in the incurring of fees or Charges or misuse of Service is the Customer's



responsibility and any such occurrences should be immediately communicated to GoldNet.

19.5 GoldNet is not responsible for the security of data passed over its networks or the Customer's computer systems. The Customer must implement all necessary security processes it deems necessary to secure or encrypt its data and computer systems and the Customer understands that it uses the Internet and any Service at its own risk of viruses, trojans and similar.

20. Minimum Term

20.1 The minimum term for any Service in the Agreement is as specified in Schedule 1 and the Application Form.

20.2 The Customer may only terminate the Agreement prior to the end of the minimum term if it first pays GoldNet the remaining fees payable under the Agreement (that is, the relevant monthly Charges multiplied by the number of months remaining in the term) plus any other outstanding fees and charges owing by the Customer to GoldNet. The Customer acknowledges this is not a penalty but is rather a reasonable estimate of the loss and damage GoldNet will suffer due to such early termination.

20.3 The Agreement rolls over on a month-to-month basis after expiry of the minimum term.

20.4 After the expiry of the minimum term, the Agreement may be terminated by either party on providing 30 days' notice.

21. Variation

21.1 GoldNet may vary the Agreement at any time.

21.2 In relation to variations that would cause detriment to Customers, the minimum period of notice to be given to Customers before the variations take effect is 60 days.

21.3 In relation to variations that would not cause detriment to Customers, the minimum period of notice to be given to Customers before the variations take effect is 30 days.

21.4 Customers will be informed of the variations via email.

21.5 An up-to-date copy of the Agreement may be obtained from GoldNet's offices or its website, <http://www.gold.net.au/legal>.

21.6 If the Customer does not approve the variations, the Customer has the right to terminate the Agreement within 60 days of the date of the notice of variation without incurring charges, other than usage or network access charges to the date the Agreement ends and outstanding amounts for installation or for equipment compatible with GoldNet's services.

21.7 Continued use of a Service will be deemed to constitute acceptance by the Customer of the variations.

22. Technical Support and Customer's Rights



- 22.1 Customers can lodge faults and complaints and seek customer support by telephoning GoldNet on (08) 90805111 Monday-Friday during normal business hours.
- 22.2 If you are not happy with our handling of a complaint, you can always contact the Telecommunications Industry Ombudsman (“TIO”) or the New South Wales Office of Fair Trading (or equivalent in your State or Territory).
- 22.3 The TIO is a free and independent alternative dispute resolution scheme for small business and residential consumers in Australia with unresolved complaints about their telephone or internet services and can be contacted by telephone on 1800 062 058 - Monday to Friday between 9am and 5pm Australian Eastern Standard Time (Free from a landline, but charged at standard mobile call rates if you call from a mobile).
- 22.4 The primary role of the New South Wales Office of Fair Trading (or equivalent in your State or Territory) is to manage consumer laws and to look after the rights of consumers.

**Schedule 1
BUSINESS DATA SERVICE**

The following Services are a range of point-to-point and point-to-multipoint data carriage services. This data is carried through our network at speeds of up to 100Mb/second.

Service	Details	Minimum Term	Fees and Charges	Customer Premises Equipment Details
VPLS:	The Virtual Private LAN Service (VPLS) offers point to point and point to multipoint layer-2 protocol independent connectivity at speeds of up to 100Mbps. VPLS allows businesses to connect multiple sites securely using either Transparent or Tagged LAN options. VPLS allows customer networks at geographically diverse locations to communicate with each other as if they were directly attached to each other over a Local Area Network.	Subject to negotiation and as specified on an Approved Application Form.	Subject to negotiation and as specified on an Approved Application Form.	
IPQMR:	The GoldNet IP 'quality of service' Managed Routed service offers a fully meshed layer-3 IP network that delivers	Subject to negotiation and as specified on an Approved Application	Subject to negotiation and as specified on an Approved Application	



	connectivity at speeds of up to 100Mb. The IPQMR service allows businesses with many sites to create and manage their own IP meshed network delivering any-to-any network topology at costs much lower than the traditional ATM or Frame relay networks.	Form.	Form.
BGNET:	The Business Grade InterNET (BGNET) offering is an affordable, faster, more reliable alternative to dial-up modem, ISDN or ADSL Internet access for business and corporate customers. BGNET bypasses contention ratios found in the ADSL Network allowing customers to utilise the full potential of the Internet.	Subject to negotiation and as specified on an Approved Application Form.	Subject to negotiation and as specified on an Approved Application Form.

The following discounts apply to monthly access charges for multiple year contracts on all GoldNet services:

Contract Term	% Discount
---------------	------------

1 year	0%
2 years	5%
3 years	10%

Schedule 2 CUSTOMER PREMISES EQUIPMENT

Each customer connected to the GoldNet network will have a CPE installed at the customer's premises.

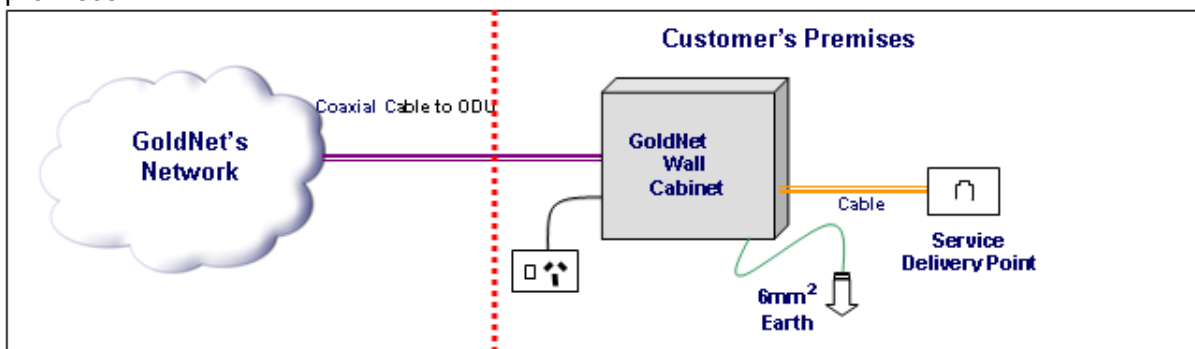

The CPE consists of two parts - an IDU (indoor unit) and an ODU (outdoor unit). The IDU consists of a cabinet that provides 6RU of rack space for housing of an Indoor Radio (1RU) a lighting protector (connected to the 1RU) a 48v dc power supply (2RU) and 4 x 12v batteries (normally 7amp hours each consuming another 2RU). If You require to be protected for longer power outages GoldNet can increase the battery size as required. A coaxial cable (cnt-400) connects the IDU to the ODU usually on the roof of the premises but may be on a tower or mast depending on the site's requirements. The length of the cable can be a maximum of 200 meters. The ODU consists of a microwave parabolic antenna (up to 1.8 metres in diameter) and a microwave outdoor radio connected to the back of this antenna (approx 25cm x 25cm x 10cm). The antenna and radio is mounted on a piece of galvanised pipe of approx 100nb. In the case of a rooftop this mount is affixed at a suitable location and engineered to achieve a 200km/hr wind loading.

The Customer must not obstruct the path between the antenna and any connection-dependant microwave tower. Furthermore the customer agrees to keep clear of 3 meters directly in front and 1 metre to the side of the antenna whilst in operation. A radiofrequency hazard sign is installed on the outdoor unit and Site Radiation Folder provided by GoldNet upon commissioning.

WARNING: THE CUSTOMER MUST NOT TAMPER WITH, REVERSE ENGINEER, RECONFIGURE, REPAIR, MODIFY OR OTHERWISE DEAL WITH THE CUSTOMER PREMISES EQUIPMENT. THE EQUIPMENT MAY CAUSE AN ELECTRICAL SHOCK WHICH MAY RESULT IN INJURY OR DEATH. THE INDOOR EQUIPMENT MUST BE KEPT IN AN ENVIRONMENTALLY FRIENDLY ENVIRONMENT WHERE THE TEMPERATURE INSIDE THE ENCLOSURE DOES NOT EXCEED 40 DEGREES CENTIGRADE. GoldNet MONITOR TEMPERATURE AND WILL LET THE CUSTOMER KNOW IF THE INDOOR UNIT GETS ABOVE 42C AND IN EXTREME CIRCUMSTANCES WE MAY REMOTELY SHUT DOWN THE EQUIPMENT IF WE FEAR THAT HEAT DAMAGE IS IMMINENT (WE DO THIS IF IT GETS UP TO 50C). AS THE SERVICE RELIES ON THE SUPPLY OF ELECTRICITY TO THE CUSTOMER PREMISES EQUIPMENT, IF ELECTRICITY POWER IS LOST OR IF THERE IS A TECHNICAL FAILURE OF THE SERVICE, THE SERVICE WILL NOT BE ABLE TO BE USED TO DIAL EMERGENCY CALL SERVICE NUMBERS OR ANY OTHER TELEPHONE NUMBERS. ACCORDINGLY, GoldNet STRONGLY ADVISES AGAINST REPLACING FIXED LINE TELEPHONE SERVICES WITH ANY VOICE-OVER IP FACILITY.

Schedule 3 SERVICE LEVELS

SERVICE UPTIME

We aim to ensure you can utilise the Service 99% of the time. Service level rebates apply in the unlikely event we cannot meet that Service Level, and amount to a percentage rebate of monthly access link charges (for the month following the breach of the 99% Service level target). The rebates are as follows:

Service uptime	Rebate on monthly fee
99.9%	Nil
95.1-99.8%	5%
90-95%	10%
<90%	15%

FAULT REPORTING

Faults can be reported 24 hours a day, 7 days a week to the GoldNet HelpDesk. We will respond to faults during the coverage times. If a fault is logged outside the coverage times then it will be treated as if it were logged at the beginning of the Coverage Period on the following Business Day.

Our Standard Fault Reporting Service Levels are as follows:

Service	Coverage Period	Response Time	Restoration Target
ALL	8am – 5pm Business Days	60 minutes	12 hours

Extended Fault Reporting Coverage, which incurs an additional monthly fee of \$250.00 includes the following Service Levels:

Service	Coverage Period	Response Time	Restoration Target
ALL	24 hours per day, 7 days per week	60 minutes	4 hours

You are eligible for a rebate when a restoration time exceeds a restoration target. The restoration time begins from when a fault is logged and ends when the Service has been reported by us to be restored.

Service level rebates apply in the unlikely event we cannot meet the Fault Reporting Service Levels, and amount to a percentage rebate of monthly access link charges (for the month following the breach of the above response and restoration targets). The rebates are as follows:

Hours over restoration target	Rebate on monthly fee
< 1 hour	5%
>1 and <4 hours	10%
4 hours or more	15%

To claim a service level rebate, you must complete a service rebate application form within one month from when the service is successfully restored.



Schedule 4 MISCELLANEOUS FEES

GoldNet charge fee-for-service Charges, for each person engaged by GoldNet to do miscellaneous work for You (in addition to work carried out in connection with our obligations under the Agreement).

The fee-for-service Charges apply where there is no Charge set out elsewhere in the Agreement. We charge you an attendance Charge, a labour Charge for each 15-minute block, and a materials charge for any materials used.

We may choose not to charge you the attendance Charge where we are already attending one of our facilities for another reason.

You may require service work to be performed outside coverage hours, or additional technical assistance in commissioning of circuits. We provide a flexible means of assisting you in meeting your support requirements.

The fee-for-service Charges are for services which may include:

- additional cabling work requested by you to be performed by our commissioning staff;
- any work requested by you that requires our onsite technical staff to attend when there is no fault associated with the Service. If it is shown on reasonable grounds through an on-site fault inspection that no fault exists with the Service, you will be charged in full for the call out;
- If you ask us to change our Equipment or cabling or your equipment in any way, including for the purpose of installation of additional cabling for the connection of your Services.

Our current fee-for-Service Charges are as follows:

\$150ex per hour between 8am and 5pm on a Business Day.

\$180ex per hour (after hours).